

Contact Information

ADD: He Yi Industry Park, Wuxing Industrial Zone, Oubei Town,
Yongjia County, Wenzhou City, Zhejiang, China

Tel: +86-577-67678989

Fax: +86-577-67678989

Cell: +86-158-6772-9999

Web: <http://www.verspec.com>

E-mail: info@verspec.com

Skype ID: verspec

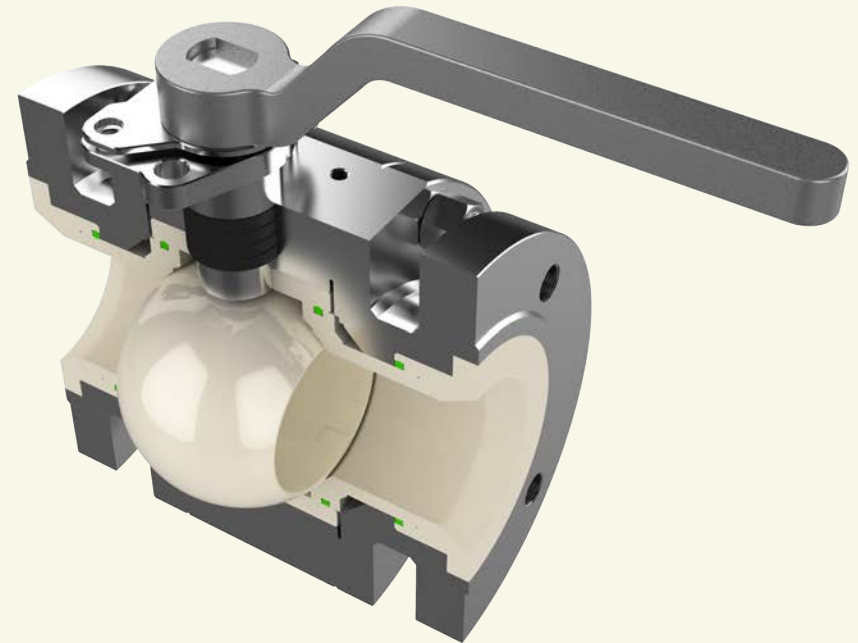

ANTI-ABRASION CERAMIC BALL VALVE



VerSpec Valve (Wenzhou) Co.,Ltd.

<http://www.verspec.com>

Why Choose a VerSpec Ceramic Ball Valve?

Due to the advanced properties of the technical ceramics used, VerSpec Ceramic Ball Valves offer significant advantages over standard material ball valves. VerSpec valves are manufactured using solid 99.5% high-purity alumina ceramic, guaranteeing a valve that is superior in all respects, including resistance to:

- **Corrosion.**

99.5% alumina ceramic is virtually inert to almost all organic and inorganic chemicals. They do not interact with, nor contaminate the process media. They are physically and chemically stable against most acids and alkalis, and offer years of service with little or no corrosive degradation.

- **Abrasion.**

99.5% alumina ceramic is 43% harder than zirconia, 140% harder than porcelain, and 730% harder than stainless steel, an indication of the long-term wear-resistance properties of our valve materials.

- **Cavitation.**

Even severe, continuous cavitation will not degrade or damage our ceramic valve components. Therefore, the VerSpec Ceramic Ball Valve may be used in cavitating or high differential-pressure Applications with little or no harmful effects.

- **Wide Selection of Trims.**

Each valve size offers a variety of four to five different control and round-ported valve trims. This assures highly accurate, tailored flow control as well as minimizing seat and pipe abrasion due to oversized trims.

- **1-Year Warranty**

By utilizing a ceramic material that is both corrosion and abrasion-resistant, we offer an extra level of security to our customers by offering up to a 1-year warranty against corrosion, abrasion, and/or faulty workmanship.



Hardness Comparison

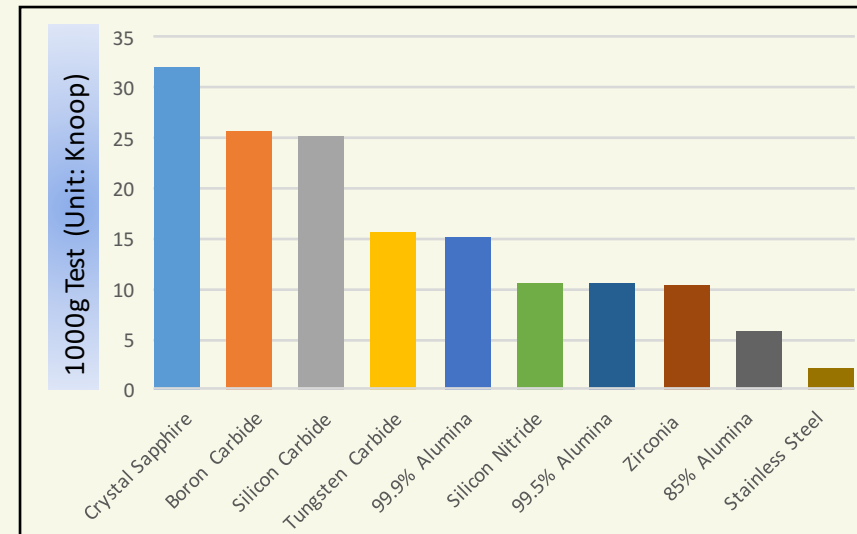

Chemical Durability Comparison Chart

Media	Temp (°C)	99.5% Al ₂ O ₃	99.9% Al ₂ O ₃	ZrO ₂	SiC	Si ₃ N ₄	SS 304	SS 316	HC®	STL #6	STL #12
20% HCL	60	A	A	A	A	B	C	C	B	C	C
20% HCL	95	A	A	A	A	C	-	-	C	C	C
90% H ₂ SO ₄	60	A	A	A	A	A	C	C	B	B	C
90% H ₂ SO ₄	95	A	A	A	A	B	C	C	C	-	-
60% H ₃ PO ₄	60	A	A	A	A	C	C	C	A	B	A
60% H ₃ PO ₄	95	A	A	A	A	C	C	C	A	C	C
10% HF	60	B	B	C	A	A	C	C	B	C	C
46% HF	95	C	C	C	A	C	-	-	C	-	-
60% HNO ₃	95	B	A	A	A	C	B	B	C	B	C
30% NaOH	60	B	A	A	A	B	A	A	A	C	A
30% NaOH	95	B	A	B	A	C	A	B	A	-	B

"A" ≤0.1mmg/cm²/day Negligible or zero corrosion, recommended for this service

"B" =0.1~0.3mmg/cm²/day Little or slight corrosion, Use with annual inspection

"C" ≥0.3mmg/cm²/day Significant corrosion, and not recommended for valve use

"-" Means test not completed due to violent corrosion

Note: ****Above charts data were obtained under controlled test conditions, and actual valve characteristics and performance may increase or decrease depending upon actual installation conditions.

N0.	Part Name	Material Name
1	Side Body	A182 F304
2	Middle Body	A182 F304
3	Ceramic Bushing	99.5% Al ₂ O ₃
4	O Ring	Viton
5	Ceramic Seat	99.5% Al ₂ O ₃
6	O Ring	Viton
7	O Ring	Viton
8	Ceramic Ball	99.5% Al ₂ O ₃
9	Ceramic Bushing	99.5% Al ₂ O ₃
10	Stem	H.C Alloy 207
11	Packing	PTFE
12	Packing Gland	SS 304
13	Positioning Bolt	A193 B8
14	Nut	A193 B8M
15	Locating Plate	SS 304
16	Stud	A193 B8
17	Stud Nuts	A193 B8M
18	Lever	SS 304

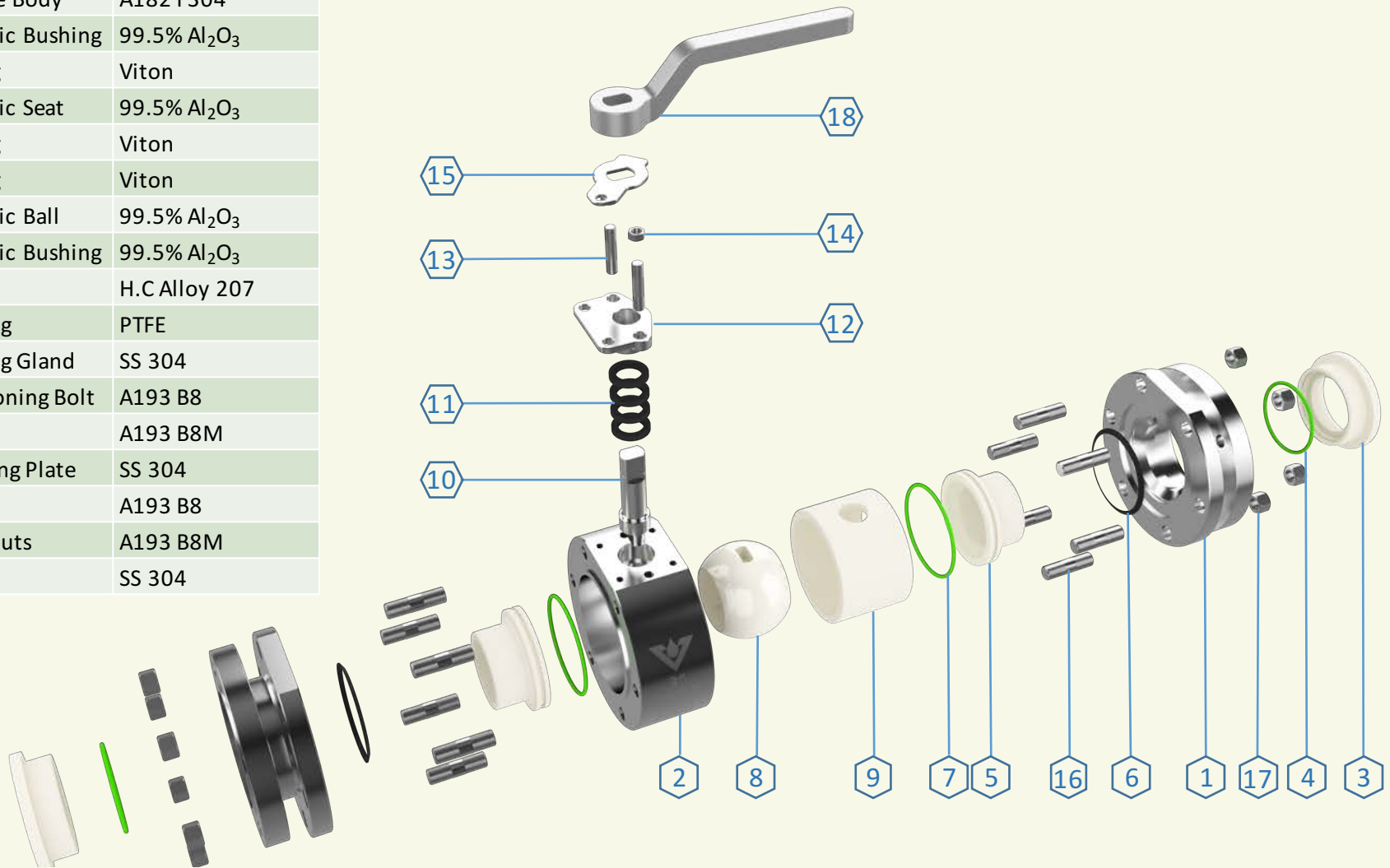

Ceramic Material Specification

99.5% Alumina. 99.5% alumina is the standard ceramic material utilized in all VerSpec ceramic valves. In addition to its extreme corrosion resistance and high hardness factor, alumina is also not subject to radioactive degradation, making it an ideal material for a wide variety of aggressive applications. It remains stable at extremely high temperatures, and may even be used for services exceeding 1,000° F.

99.9% Alumina. This high-grade alumina is one of the purest forms of alumina available. It has a finer particle size, is more homogenous, and has less binding material than the 99.5% alumina. As a result, the corrosion and abrasion resistance properties are dramatically increased, making this ceramic an ideal choice for the most severe services, while still maintaining a low purchase cost.

Zirconia. Zirconia has the highest strength and toughness at room temperature of all engineered ceramics. However, zirconia is less corrosion resistant and more susceptible to impingement and rubbing wear, and is therefore used primarily for high torque and/or high pressure applications.

Silicon Carbide. Silicon carbide is only next to diamond and boron carbide in hardness, and 95% harder than our standard alumina. It exhibits high thermal conductivity, high thermal-shock resistance, and strength durability at extreme temperatures. Silicon carbide has the highest corrosion resistance of all fine ceramic materials, and is also one of the few that is resistant to HF, making this material the ceramic of last resort.

Performance Data

Specification	Density	Hardness	Bending Strength	Max Temp	Liner Expansivity	Elastic Modulus	Thermal Conductivity	
Unit	g/cm ³	HRA≥	Mpa≥	°C	X10 ⁶ /°C	Gpa	20	
Al ₂ O ₃ Purity	≥95%	3.7	86	300	1500	7.5	300	25
	≥99%	3.8~3.85	88	350	1500	8.2	350	25
	≥99.5%	3.85	88	400	1500	8.2	350	25
	≥99.8%	3.9	88	400	1500	8.2	350	25
ZrO ₂	TZP	5.95	87	1150	500	9.6	210	
	ARZ	5.3	87	800	800	9.6	210	

Design & Manufacturing: ASME B16.34

Face to face: ASME B16.10

End Flange: ASME B16.5

Inspection and Test: API 598

Pressure Test	Shell Test	1.5	Mpa
	Seal Test	1.1	
	Air Test	0.6	
Applicable Medium		Corrosive medium with solids	

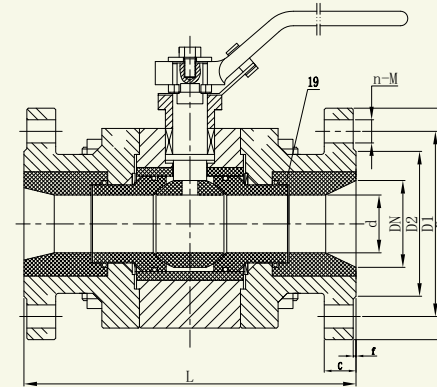

Connection Data

NPS	L	d	D	D1	D2	C	f	H	n-M
1/2"	108	10	89	60.5	35	11.2	1.6	80	4-M14
3/4"	117	15	99	70	43	12.7	1.6	92	4-M14
1"	127	20	108	79.5	51	14.2	1.6	110	4-M14
1-1/2"	165	32	127	98.5	73	15.7	1.6	142	4-M14
2"	178	40	152.5	120.5	92	19	1.6	185	4-M16
2-1/2"	190	50	178	140	105	19	1.6	210	4-M16
3"	203	65	190	152.5	127	24	1.6	230	4-M16
4"	229	80	229	190.5	157	24	1.6	265	8-M16
5"	245	100	254	216	186	24	1.6	305	8-M20
6"	267	125	279	241.5	216	25.4	1.6	340	8-M20
8"	292	150	340	298.5	270	28.4	1.6	420	8-M20